

# STEEP SLOPE DRAINAGE CHANNEL AND CHANNEL CLIP

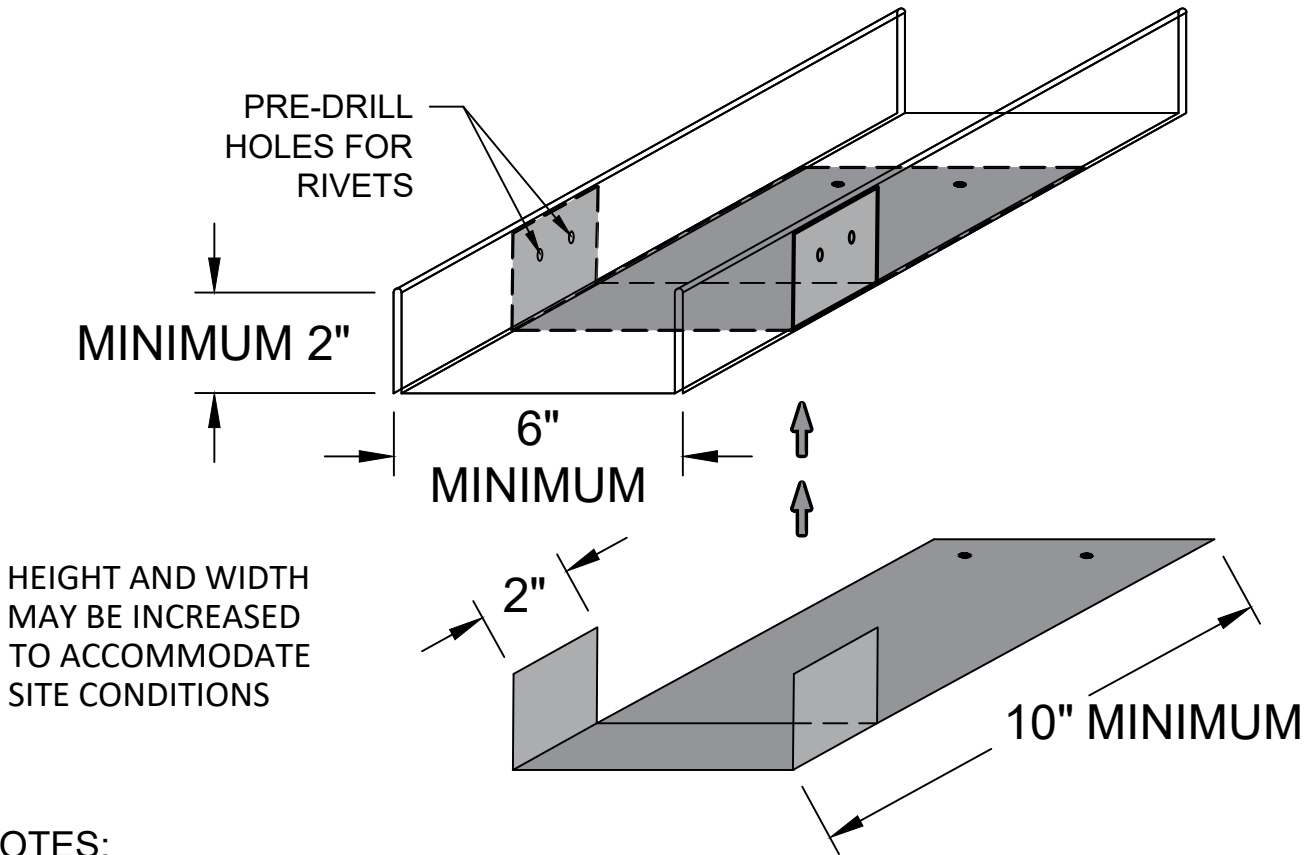

HEIGHT AND WIDTH  
MAY BE INCREASED  
TO ACCOMMODATE  
SITE CONDITIONS

## NOTES:

- DRAINAGE CHANNEL AND CLIP TO BE SHOP-FABRICATED; 24 GA. AN ENCLOSED TROUGH OR DOWNSPOUT ARE ALSO ACCEPTABLE.
- FASTEN CHANNEL CLIP FLANGE TO ROOF DECK WITH #10 x 1" PAN-HEAD SCREWS.
- STRIP-OFF FLANGE WITH ARCTIC SEAL SELF-ADHERING UNDERLAYMENT.
- INSTALL SHINGLES TO OVERLAP FLANGE; SEAL SHINGLES TO FLANGE.
- BEGIN INSTALLATION OF DRAINAGE CHANNEL SEGMENTS AT LOW POINT OF ROOF AND WORK UPWARD, UPPER PIECES OVERLAPPING LOWER PIECES BY 6" MINIMUM; EMBED IN STRUCTURAL SEALANT.
- FASTEN CHANNEL CLIPS TO DRAINAGE CHANNEL WITH POP RIVETS; PRE-DRILL HOLES.
- INSTALL CHANNEL CLIPS EVERY 10' O.C. AND ONE AT BOTH ENDS.
- POSITION UPPER END OF DRAINAGE CHANNEL UNDER DOWNSPOUT FROM UPPER ROOF.

## STEEP SLOPE 32



Rev. 4/24

PROJECT NAME:

ADDRESS:

OWNER:

DATE:

SCALE: NOT TO SCALE

PROJECT NO:

DRAWING NO. :

SUBMITTAL NO. :